

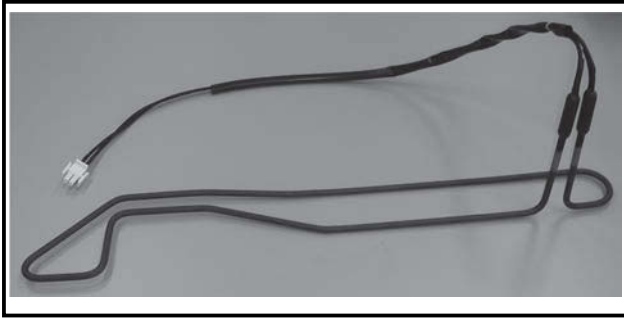

Freeze-prevention heater (for drain pan) MAC-643BH-E

Photo



Dimensions

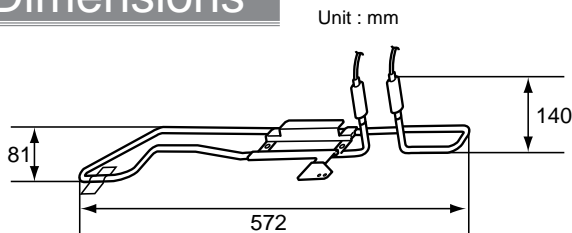

Descriptions

It is freeze-prevention heater for the outdoor unit of the air conditioner.

Applicable Models

■ MUZ-EF42VE

Specifications

Rated voltage	230 V 50 Hz
Power consumption	130 W

Components

① Defrost heater	1	⑤ Self drilling screw	2
② Aluminum tape	1	⑥ Insulation	1
③ Heater support	1	⑦ Wiring diagram	1
④ Cable tie	1	⑧ Spec label	1

How to Use / How to Install

1. INSTALLING THE HEATER

- Hold the left lower side of the heat exchanger, and slightly lift up the heat exchanger.
- Insert the defrost heater ① under the heat exchanger, and align it with the groove on the base.
After positioning the defrost heater ①, secure it to the base with the aluminum tape ②. In order to fix the defrost heater to the base, fix the heater support ③ to the base with 2 self drilling screws ⑤.
- Put the heat exchanger back in place, and install the motor support and the propeller fan. (Refer to the figure below for details.)

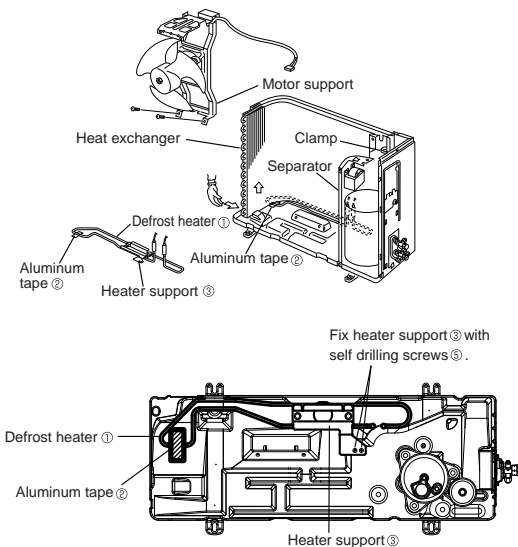

2. FIXING THE WIRES

- Place the lead wires of the defrost heater ①, fan motor, and ambient temp. thermistor as shown in the figure below. Secure them with the cable tie ④.
*If the lead wires slacken, there is a possibility that they touch the propeller fan. Be sure to secure the wires with the cable tie ④ and a clamp for safety. Cut off the surplus of the cable tie ④.
- Apply the insulation ⑥ on the place indicated in the figure below. Secure all the wires tightly with the clamp.
- Install the elect assy on the fixed place.
Connect the lead wires from the defrost heater ① to CN 722 on the inverter P.C. board.

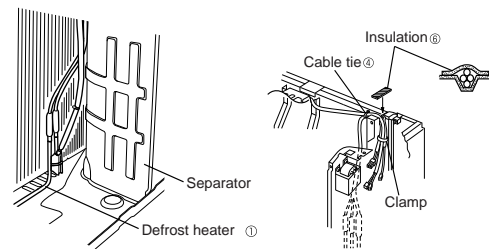

OPTIONAL PARTS